

THIS DRAWING IS THE PROPERTY OF PRIMARY FLUID SYSTEMS INC. FROM WHICH A WRITTEN CONSENT FOR APPROVAL SHALL BE REQUIRED PRIOR TO COPYING.

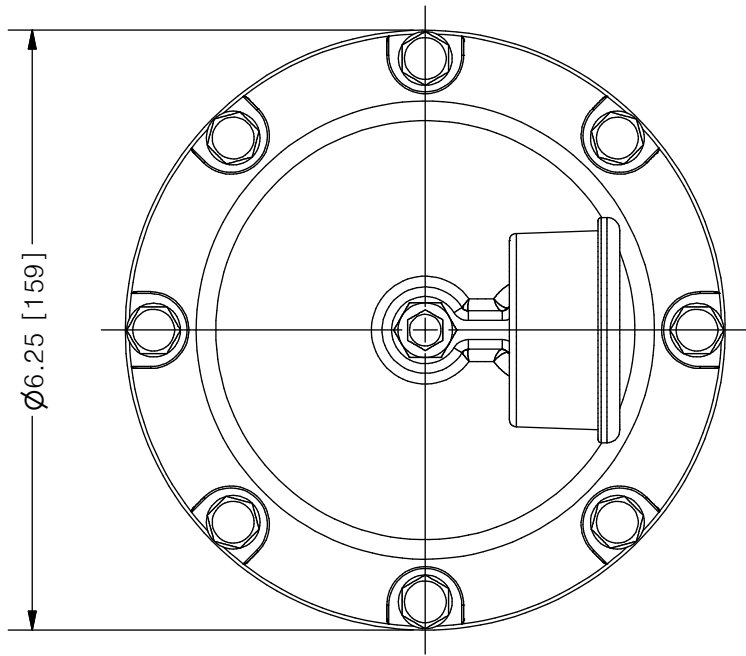

ACCU-PULSE®
APII PULSATION DAMPENER

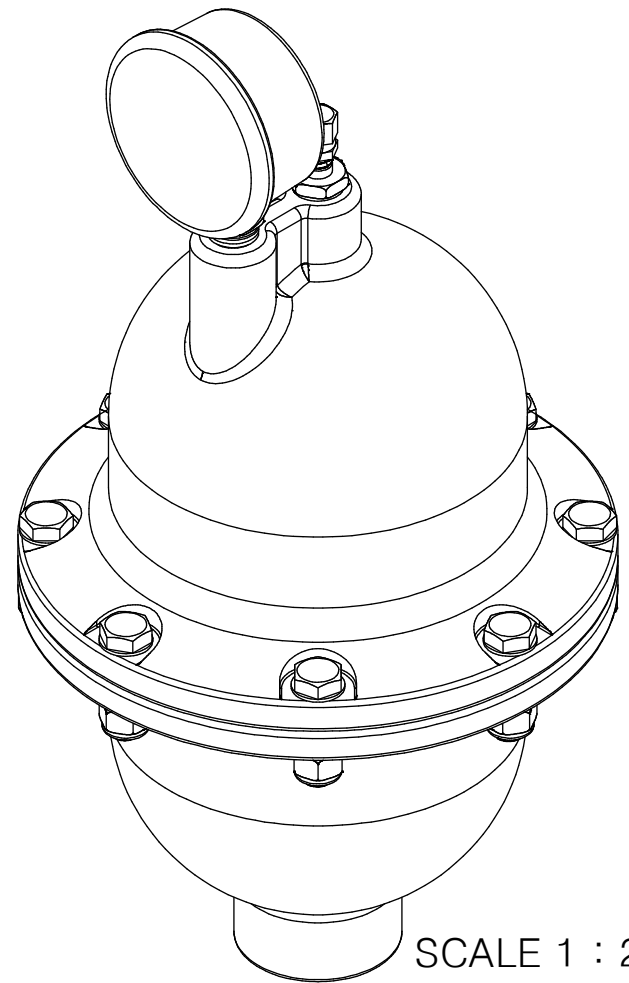

SCALE 1 : 2

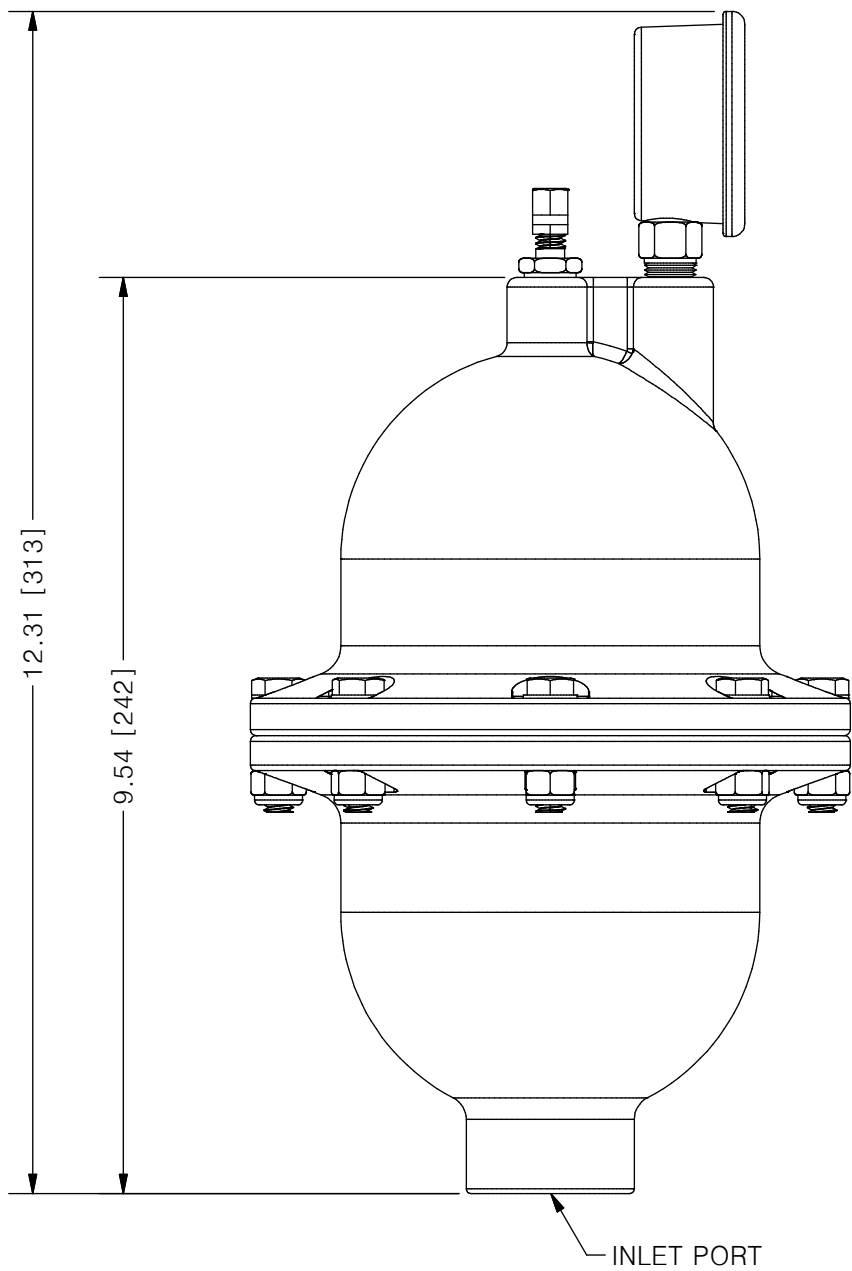

AVAILABLE BLADDER/BELLOW	
EPDM	
VITON	
NEOPRENE	
BUNA-N	
HYPALON	
PTFE (MAX 150 PSIG)	

NO.	NAME	DESCRIPTION
1	MAX ALLOWABLE OPERATING PRESSURE	300PSI @ 70°F (21°C)
2	UNIT CAPACITY	85 CU IN
3	INLET PORT	3/4" (1" OPTIONAL)
4	CONNECTION TYPE	NPT
5	BOTTOM HOUSING (WETTED)	316 S/S / C276 / ALLOY 20
6	BLADDER (WETTED)	SEE CHART ABOVE
7	TOP HOUSING	316 S/S
8	GAUGE CASE/BACKING	STAINLESS STEEL AND BRASS
9	FILL VALVE	STAINLESS STEEL

PRIMARY FLUID SYSTEMS INC. 1050 COOKE BLVD., BURLINGTON, ONTARIO L7T 4A8	PROJECT: AP	SHT: 1 OF 1	DRAWN BY: NIKHIL G
	DATE DRAWN: 8/15/2016	SCALE: 1 : 2	UNITS: INCH[mm]
TITLE: ACCU-PULSE II PULSATION DAMPENER	MATERIAL: SEE CHART	DWG NO.: APII-ALLOY_RI	REVISION: 1
DWG NAME: APII	APPROVED BY:	CHECKED BY:	DIMENSIONAL TOLERANCE 0.XX ± 0.25"
DWG TYPE: PLANAR VIEW 2D			

11 X 17 SHEET SIZE: **B**