

THIS DRAWING IS THE PROPERTY OF PRIMARY FLUID SYSTEMS INC. FROM WHICH A WRITTEN CONSENT FOR APPROVAL SHALL BE REQUIRED PRIOR TO COPYING.

	NO.	NAME	DESCRIPTION
	1	MAX ALLOWABLE OPERATING TEMPERATURE	140°F (60°C)
	2	MAX ALLOWABLE OPERATING PRESSURE	15 PSIG
	3	LEAK TEST	YES
CONNECTIONS	4	BOTTOM PORT CONNECTION	1/2"
	5	TOP PORT CONNECTION	DUST CAP
	6	TYPE	ASTM FLANGE
MATERIALS	7	CYLINDER	POLYPROPYLENE
	8	END CAPS	POLYPROPYLENE
INPUT DATA	12	VOLUME SIZE	250 ML
SCALE	13	GRADUATION	2 ML
COMMENTS	15	ALL CYLINDERS ARE RATED FOR LIQUID SERVICE ONLY	√
	16	CYLINDERS ARE NOT PRESSURE VESSELS	√

ACCUDRAW® AC#3 POLYPROPYLENE CALIBRATION CYLINDER

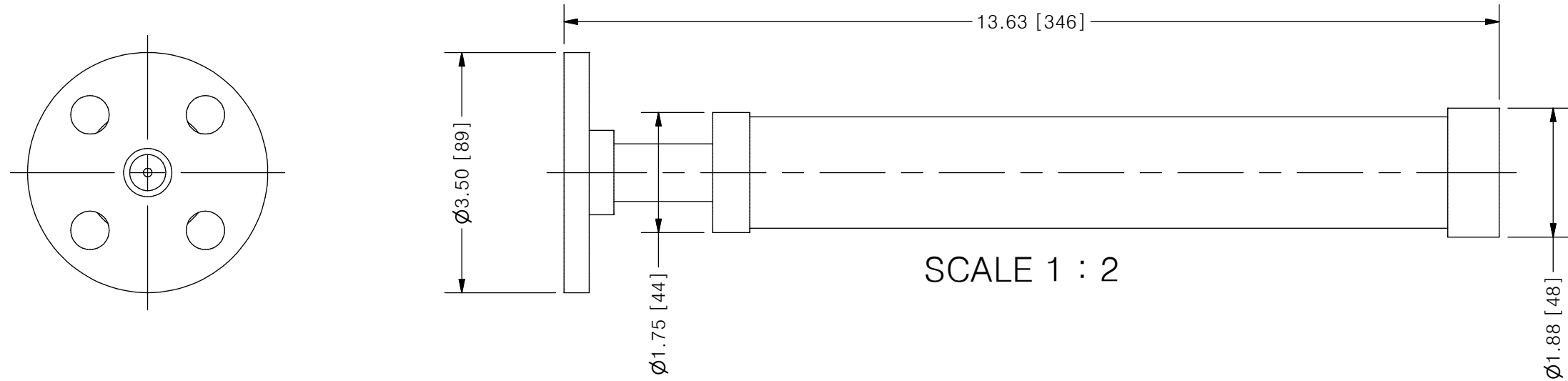

REV	DESCRIPTION	DATE	NAME
2	NEW DRAWING	--	--

REVISION HISTORY

PRIMARY FLUID SYSTEMS INC. 1050 COOKE BLVD, BURLINGTON, ONTARIO L7T 4A8		PROJECT: AC	SHT: 1 OF 1	DRAWN BY: NG
TITLE: 250 ML CALIBRATION CYLINDER WITH 1/2" ASTM FLANGE		DATE DRAWN: 7/15/2016	SCALE: 1 : 2	UNITS: INCH [mm]
DWG NAME: AC CYLINDER DWG TYPE: PLANAR VIEW		MATERIAL: SEE CHART	DWG NO: AC#3-250-F_R2	REV# 2
APPROVED BY: _____ CHECKED BY: _____		DIMENSIONAL TOLERANCE 0.X = ± 0.25" 0.XX = ± 0.25" 0.XXX = ± 0.25"		SHEET SIZE: B