

THIS DRAWING IS THE PROPERTY OF PRIMARY FLUID SYSTEMS INC. FROM WHICH A WRITTEN CONSENT FOR APPROVAL SHALL BE REQUIRED PRIOR TO COPYING.

	NO.	NAME	DESCRIPTION
	1	MAX ALLOWABLE OPERATING TEMPERATURE	140°F (60°C)
	2	MAX ALLOWABLE OPERATING PRESSURE	15 PSIG
	3	LEAK TEST	YES
CONNECTIONS	4	BOTTOM PORT CONNECTION	2"
	5	TOP PORT CONNECTION	2"
	6	TYPE	FLANGE ANSI B16.5
MATERIALS	7	CYLINDER	GLASS
	8	END CAPS	CPVC
	9	GLASS SEALING 'O' RINGS	VITON
MATERIAL NON WETTED	10	OUTER SHIELD	POLYCARBONATE
	11	SHIELD SEALING 'O' RINGS	BUNA-N
INPUT DATA	12	VOLUME SIZE	20000 ML
SCALE	13	GRADUATION	200 ML
COMMENTS	14	ALL CYLINDERS ARE RATED FOR LIQUID SERVICE ONLY	
	15	CYLINDERS ARE NOT PRESSURE VESSELS	

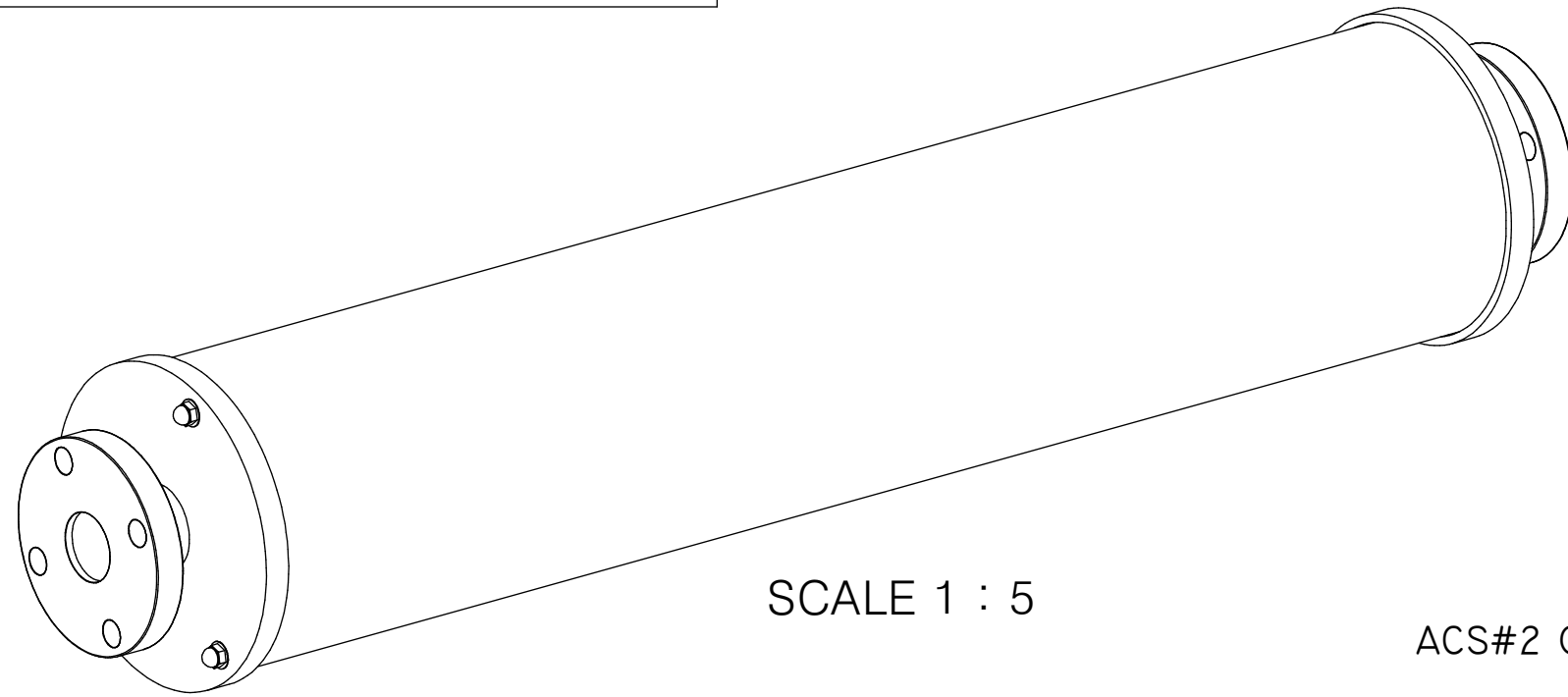

SCALE 1 : 5

ACCUDRAW®
ACS#2 GLASS CALIBRATION CYLINDER

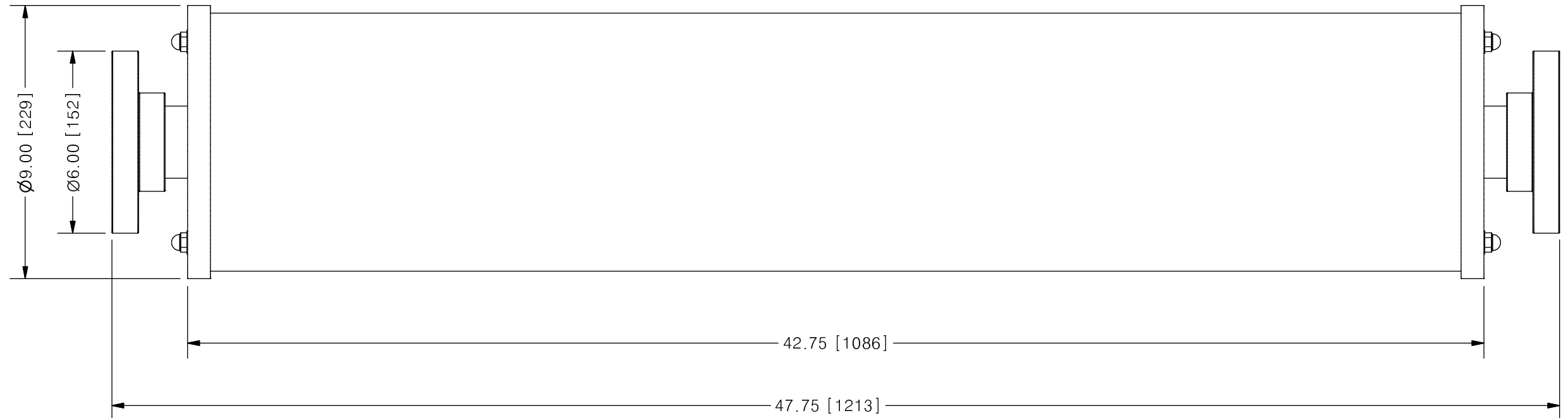
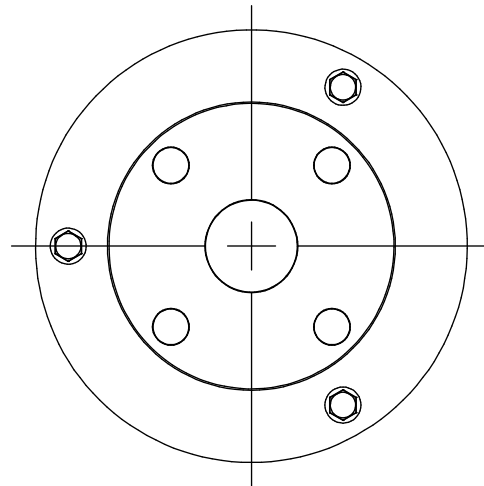

SCALE 1 : 4

REV	DESCRIPTION	DATE	NAME
0	NEW DRAWING	--	--

REVISION HISTORY

PRIMARY FLUID SYSTEMS INC. 1050 COOKE BLVD, BURLINGTON, ONTARIO L7T 4A8		PROJECT: ACS	SHT: 1 OF 1	DRAWN BY: BRJB
TITLE: 20000 ML CALIBRATION CYLINDER WITH 2" FLANGE CONNECTION		DATE DRAWN: 6/13/2017	SCALE: 1 : 4	UNITS: INCH [mm]
DWG NAME: ACS CYLINDER DWG TYPE: PLANAR VIEW		MATERIAL: SEE CHART	DWG NO: ACS#2-20000-GCV-F_R0	REV# 0
APPROVED BY: _____ CHECKED BY: _____		DIMENSIONAL TOLERANCE 0.XX = ± 0.25" 0.XXX = ± 0.25" 0.XXX = ± 0.25"		SHEET SIZE: B

