

NOTE: SERIAL NUMBER & MODEL REQUIRED FOR PARTS ORDER

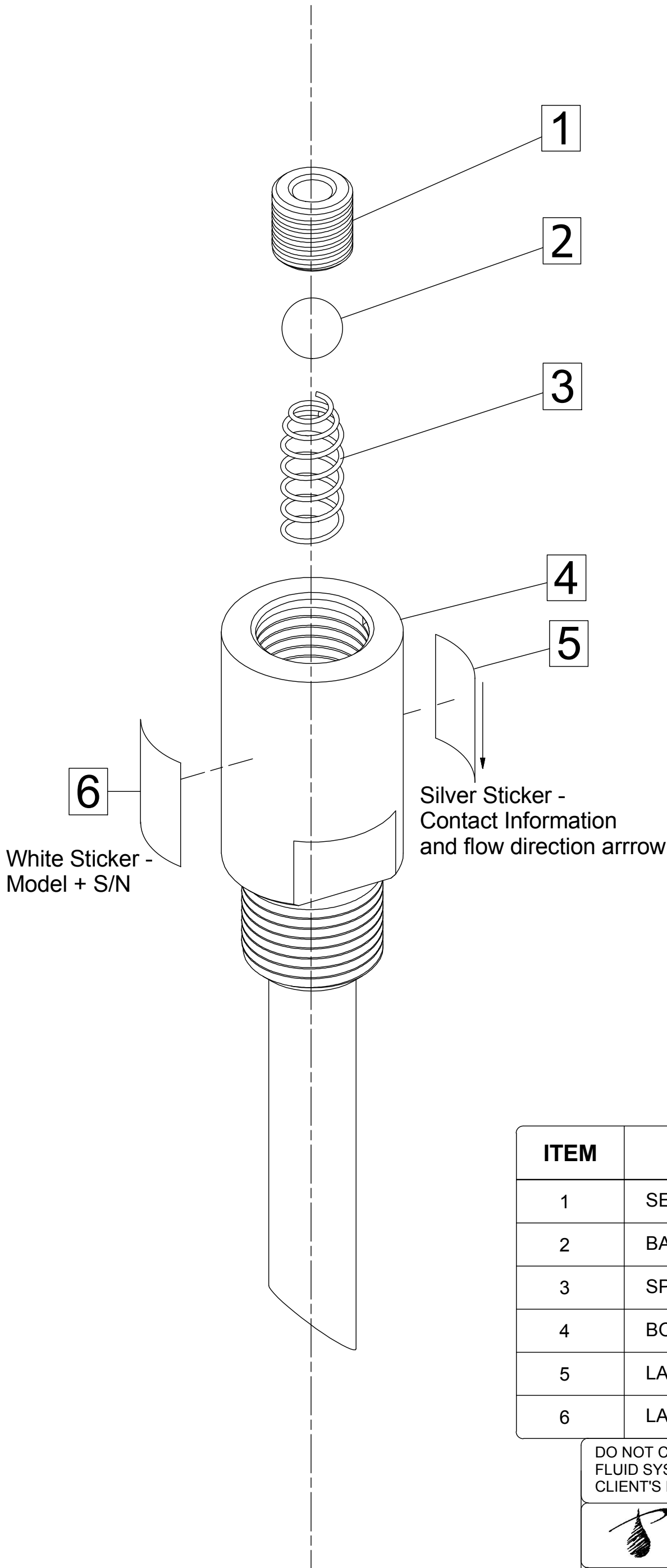

MATERIAL/SIZE CODING

W = PVC = (PVC)

W = CPVC = (CPVC CORZAN)

W = PP = (POLYPROPYLENE)

W = PVDF = (PVDF)

X = CR = (CERAMIC)

X = GFTFE = (25% OF GF PTFE)

X = PVDF = (PVDF)

X = S/S6 = (316 STAINLESS STEEL)

X = HAST = (HASTELLOY C276)

X = TITA = (TITANIUM GR.2)

Y = S/S6 = (316 STAINLESS STEEL)

Y = HAST = (HASTELLOY C276)

Y = TITA = (TITANIUM BETA C)

Z = 3" INSERTION UNITS

Z = 5" INSERTION UNITS

Z = OTHER THAN STANDARD LENGTH

CONTACT FACTORY

^ = P = (PVC)

^ = C = (CPVC CORZAN)

^ = PP = (POLYPROPYLENE)

^ = K = (PVDF)

White Sticker -
Model + S/N

Silver Sticker -
Contact Information
and flow direction arrow

ITEM	DESCRIPTOIN	PART NUMBER
1	SEAT, CHECK	IQF - 1W - SEAT
2	BALL, CHECK	IQF - 1X - BALL
3	SPRING, CHECK	IQF - 1Y - SPRING
4	BODY, QUILL	IQF - 5Z - ^
5	LABEL, DIRECTION, SILVER	IQF - LABEL - DIR
6	LABEL, MODEL + SERIAL #	MSLABEL

DO NOT COPY WITHOUT PRIOR WRITTEN APPROVAL FROM PRIMARY FLUID SYSTEMS. ACCEPTABILITY OF SPECIFICATIONS ARE THE CLIENT'S RESPONSIBILITY.



Primary Fluid Systems Inc.

**PFS INJECTION QUILL - PLASTIC
EXPLODED VIEW**

SCALE	DISC	DRAWN BY	
DATE	APPROVED	DWG NO.	REV. #
PROJECT			