

THIS DRAWING IS THE PROPERTY OF PRIMARY FLUID SYSTEMS INC. FROM WHICH A WRITTEN CONSENT FOR APPROVAL SHALL BE REQUIRED PRIOR TO COPYING.

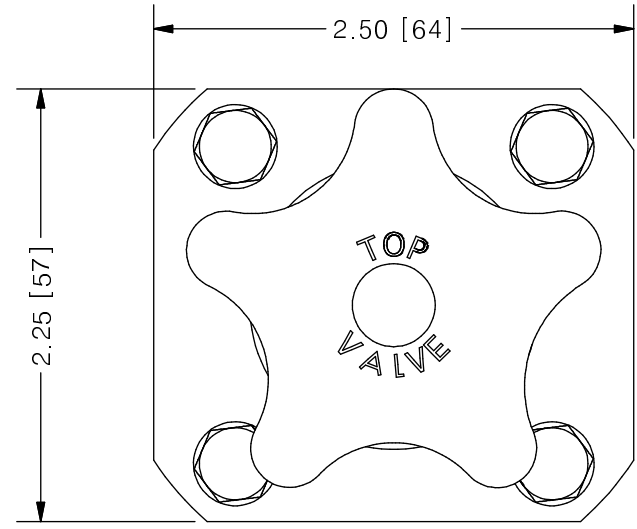

TOP VALVE® TVB BACK PRESSURE VALVE

	NO.	NAME	DESCRIPTION
	1	MAX ALLOWABLE OPERATING TEMPERATURE	180°F (82°C)
	2	MAX ALLOWABLE OPERATING PRESSURE	150 PSIG @ 70°F
CONNECTIONS	3	SIZE: INLET/OUTLET	1/2"
	4	CONNECTION TYPE	NPT
MATERIALS (WETTED)	5	BODY	316 SS
	6	DIAPHRAGM	PTFE BACKED EPDM
MATERIALS (NON-WETTED)	7	SPRING BONNET/TOP	CPVC
	8	SPRING	NICKEL PLATED MUSIC WIRE ASTM A228
	9	TOP/BOTTOM DISC	POLYPROPYLENE
	10	BOLTS, NUTS, WASHERS	STAINLESS STEEL
	11	FACTORY SET PRESSURE	50 PSIG
	12	SPRING RANGE	7-150 PSIG

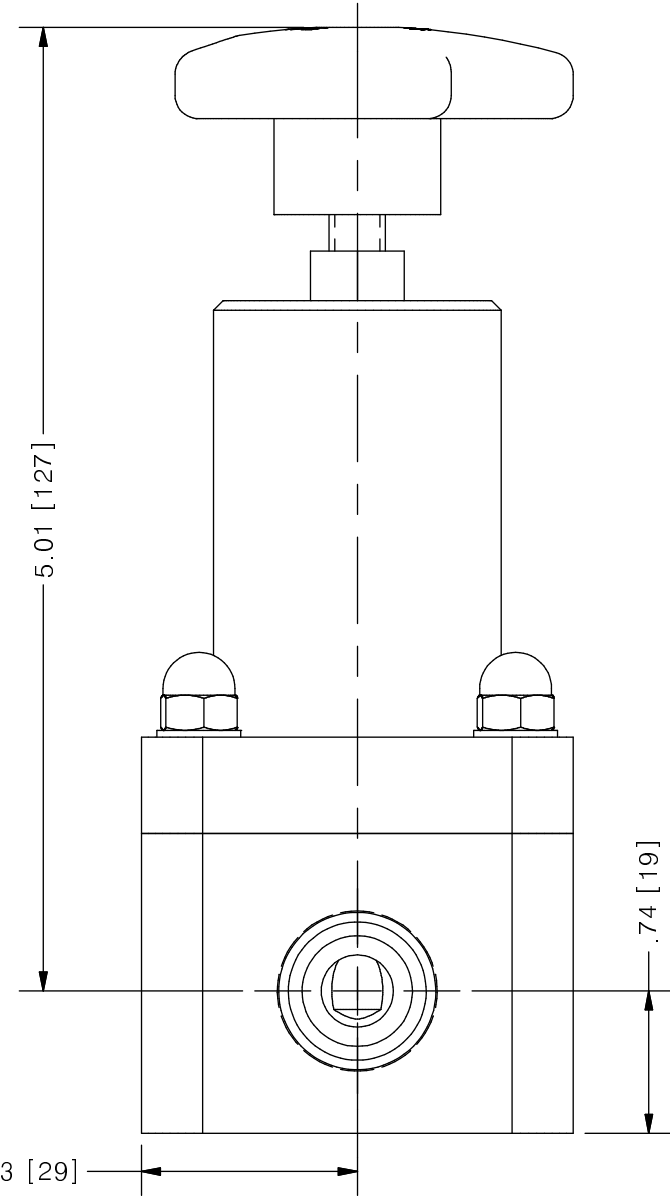
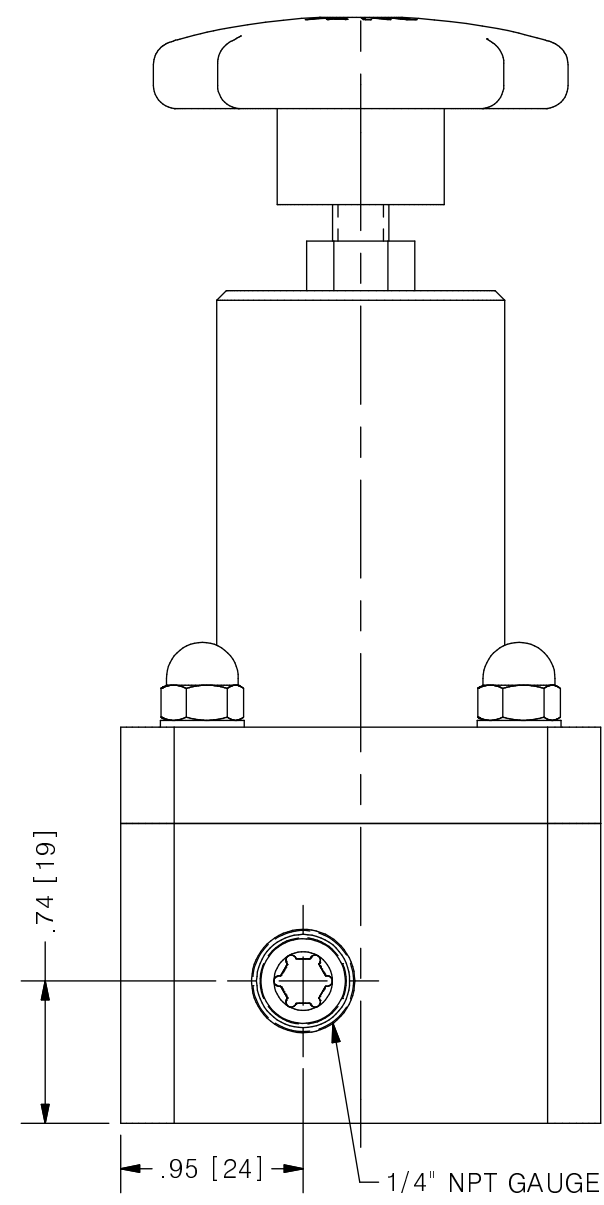

SCALE 1 : 1

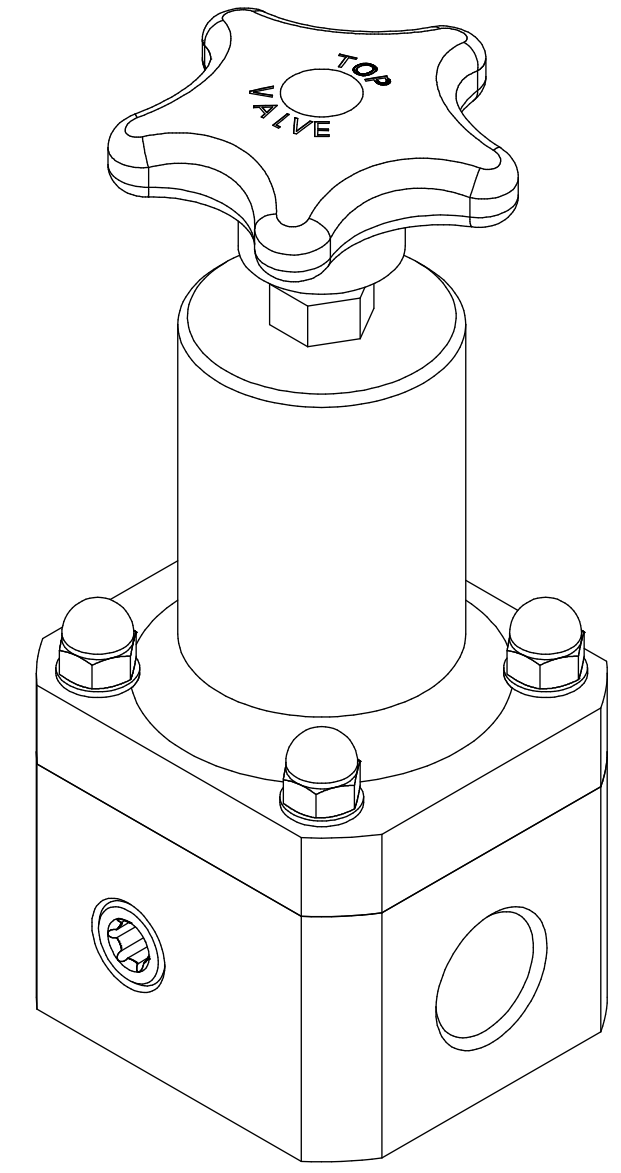

REV	DESCRIPTION	DATE	NAME
0	NEW DRAWING	--	--

PRIMARY FLUID SYSTEMS INC. 1050 COOKE BLVD, BURLINGTON, ONTARIO L7T 4A8		PROJECT: TVB	SHT: 1 OF 1	DRAWN BY: NG
TITLE: 1/4" BACK PRESSURE TOP VALVE WITH 1/2" NPT CONNECTIONS PLUS GAUGE PORT		DATE DRAWN: 7/5/2016	SCALE: 1 : 1	UNITS: INCH [mm]
DWG NAME: TOP VALVE DWG TYPE: PLANAR VIEW		MATERIAL: SEE CHART	DWG NO: TVBP45-SS-G_R0	DIMENSIONAL TOLERANCE 0.X = ± 0.25" 0.XX = ± 0.25" 0.XXX = ± 0.25"
APPROVED BY: _____ CHECKED BY: _____		THIRD ANGLE PROJECTION		REV# 0 SHEET SIZE: B