

THIS DRAWING IS THE PROPERTY OF PRIMARY FLUID SYSTEMS INC. FROM WHICH A WRITTEN CONSENT FOR APPROVAL SHALL BE REQUIRED PRIOR TO COPYING.

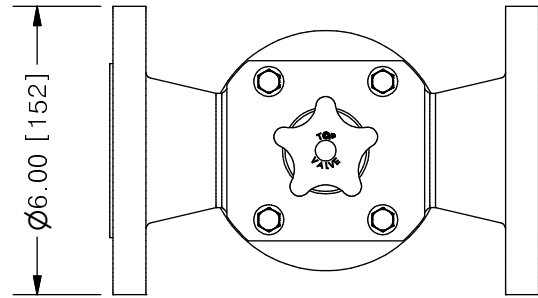

TOP VALVE® TVP PRESSURE RELIEF VALVE

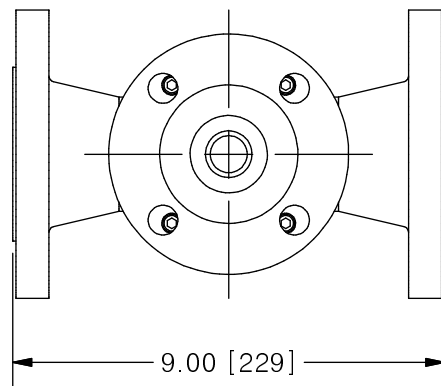
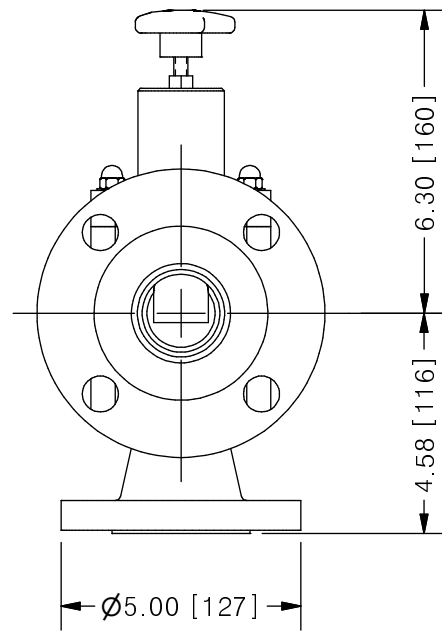
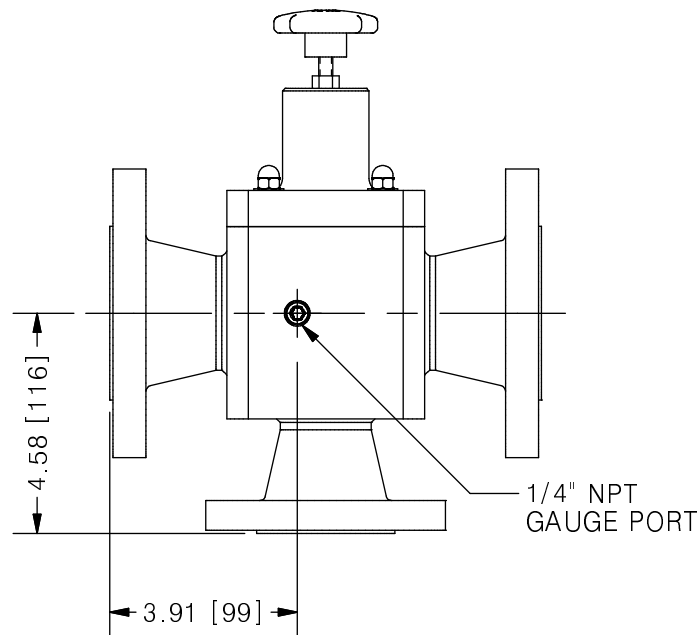

SCALE 1 : 4

| NO. | NAME | DESCRIPTION |
|------------------------|-------------------------------------|---|
| 1 | MAX ALLOWABLE OPERATING TEMPERATURE | 140°F (60°C) |
| 2 | MAX ALLOWABLE OPERATING PRESSURE | 150 PSIG @ 70°F |
| CONNECTIONS | | |
| 3 | SIZE: INLET/OUTLET PORTS | 2" |
| 4 | SIZE: RELIEF PORT | 1-1/2" |
| 5 | CONNECTION TYPE | ANSI FLANGE 150# RF B16.5 |
| MATERIALS (WETTED) | | |
| 6 | BODY | STAINLESS STEEL |
| 7 | DIAPHRAGM | PTFE BACKED EPDM (PVC, EPDM AND VITON OPTIONAL) |
| 8 | FLANGES | STAINLESS STEEL |
| MATERIALS (NON-WETTED) | | |
| 9 | SPRING BONNET/TOP | PVC |
| 10 | SPRING | NICKEL PLATED MUSIC WIRE ASTM A228 |
| 11 | TOP/BOTTOM DISC | POLYPROPYLENE |
| 12 | BOLTS, NUTS, WASHERS | STAINLESS STEEL |
| 13 | FACTORY SET PRESSURE | 50 PSIG |
| 14 | SPRING RANGE | 7-150 PSIG |

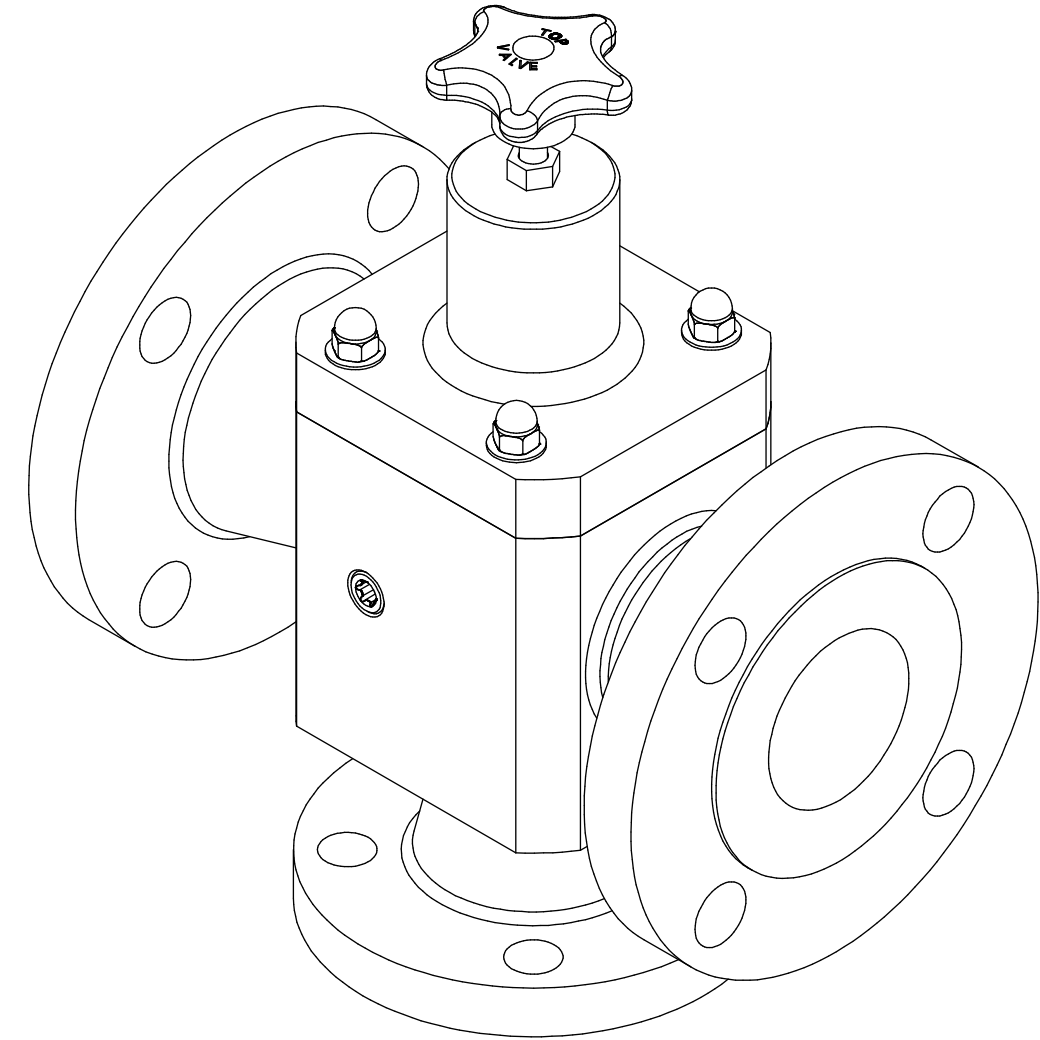

SCALE 1 : 2

| PRIMARY FLUID SYSTEMS INC. 1050 COOKE BLVD, BURLINGTON, ONTARIO L7T 4A8 | | PROJECT: TVP | SHT: 1 OF 1 | DRAWN BY: NG | | | | | | | | |
|--|-------------|---|-------------------------|---|-----|-------------|------|------|---|-------------|----|----|
| TITLE: 2" PRESSURE RELIEF TOP VALVE WITH 2" AND 1-1/2" 150# WN FLANGES PLUS GAUGE PORT | | DATE DRAWN: 7/28/2016 | SCALE: 1 : 4 | UNITS: INCH [mm] | | | | | | | | |
| DWG NAME: TOP VALVE DWG TYPE: PLANAR VIEW | | MATERIAL: SEE CHART | DWG NO: TVPFW20-SS-G_R0 | DIMENSIONAL TOLERANCE 0.XX = ± 0.25" 0.XXX = ± 0.25" 0.XXX = ± 0.25" | | | | | | | | |
| APPROVED BY: _____ CHECKED BY: _____ | | REVISION HISTORY <table border="1"> <thead> <tr> <th>REV</th> <th>DESCRIPTION</th> <th>DATE</th> <th>NAME</th> </tr> </thead> <tbody> <tr> <td>0</td> <td>NEW DRAWING</td> <td>--</td> <td>--</td> </tr> </tbody> </table> | | | REV | DESCRIPTION | DATE | NAME | 0 | NEW DRAWING | -- | -- |
| REV | DESCRIPTION | DATE | NAME | | | | | | | | | |
| 0 | NEW DRAWING | -- | -- | | | | | | | | | |