

THIS DRAWING IS THE PROPERTY OF PRIMARY FLUID SYSTEMS INC. FROM WHICH A WRITTEN CONSENT FOR APPROVAL SHALL BE REQUIRED PRIOR TO COPYING.

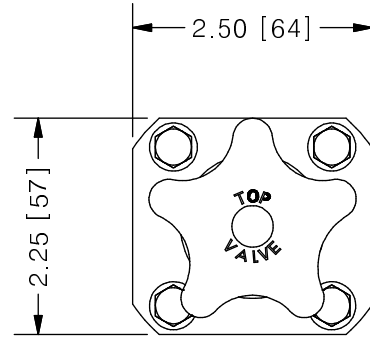

TOP VALVE® TVP PRESSURE RELIEF VALVE

NO.	NAME	DESCRIPTION
1	MAX ALLOWABLE OPERATING TEMPERATURE	180°F (82°C)
2	MAX ALLOWABLE OPERATING PRESSURE	150 PSIG @ 70°F
CONNECTIONS		
3	SIZE: INLET/OUTLET PORTS	1/2"
4	SIZE: RELIEF PORT	1/4"
5	CONNECTION TYPE	NPT
MATERIALS (WETTED)		
6	BODY	316 SS
7	DIAPHRAGM	PTFE BACKED EPDM
MATERIALS (NON-WETTED)		
8	SPRING BONNET/TOP	CPVC
9	SPRING	NICKEL PLATED MUSIC WIRE ASTM A228
10	TOP/BOTTOM DISC	POLYPROPYLENE
11	BOLTS, NUTS, WASHERS	STAINLESS STEEL
12	FACTORY SET PRESSURE	50 PSIG
13	SPRING RANGE	7-150 PSIG

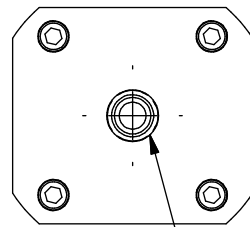
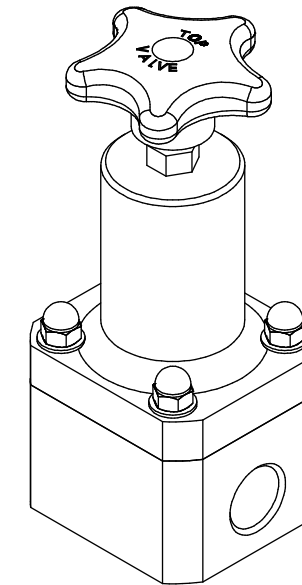
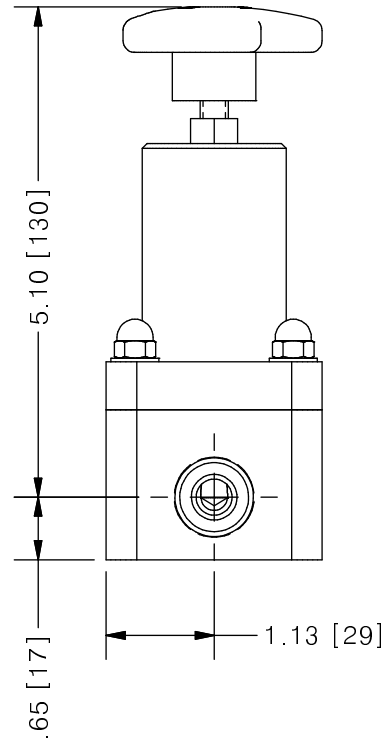
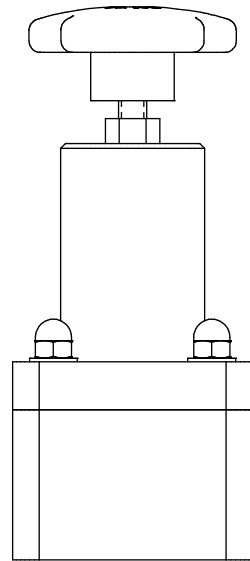

1/4" RELIEF PORT

SCALE 1 : 2

REV	DESCRIPTION	DATE	NAME
0	NEW DRAWING	--	--

PRIMARY FLUID SYSTEMS INC. 1050 COOKE BLVD, BURLINGTON, ONTARIO L7T 4A8		PROJECT: TVP	SHT: 1 OF 1	DRAWN BY: NG
TITLE: 1/4" PRESSURE RELIEF TOP VALVE WITH 1/2" NPT CONNECTIONS AND 1/4" RELIEF PORT.		DATE DRAWN: 7/27/2016	SCALE: 1 : 2	UNITS: INCH [mm]
DWG NAME: TOP VALVE		MATERIAL: SEE CHART	DWG NO: TVPR45-SS_R0	REV# 0
DWG TYPE: PLANAR VIEW		APPROVED BY:	CHECKED BY:	DIMENSIONAL TOLERANCE 0.X = ± 0.25" 0.XX = ± 0.25" 0.XXX = ± 0.25"
				SHEET SIZE: B