

DIMENSIONS (INCHES)

SIZE	OVERALL			INLET/OUTLET		GAGE PORT (OPTIONAL)		
	A*	B***	C	D	E	F***	G***	H
1/4" x 1/2"	6.85	5.00	3.50	1.75	1.75	2.50	2.20	1.75
1/2"	7.35	6.75	3.50	1.75	1.75	3.375	2.849	1.75
3/4"	7.54	6.75	3.88	1.94	1.94	3.375	2.849	1.94
1"	7.825	7.50	4.25	2.125	2.125	3.75	3.28	2.125
1.5"	8.56	7.625	5.00	2.50	2.50	3.813	3.218	2.50
2"	9.30	9.03	6.00	3.00	3.00	4.513	3.918	3.00

* DIMENSIONS ARE APPROXIMATE FOR OVERALL HEIGHT BASED ON VALVE FACTORY SET AT 50 PSIG.

*** B, F & G DIMENSIONS BASED ON FLAT FACE FLANGES. SUBJECT TO CHANGE WITHOUT NOTICE TOLERANCE +/- .25"

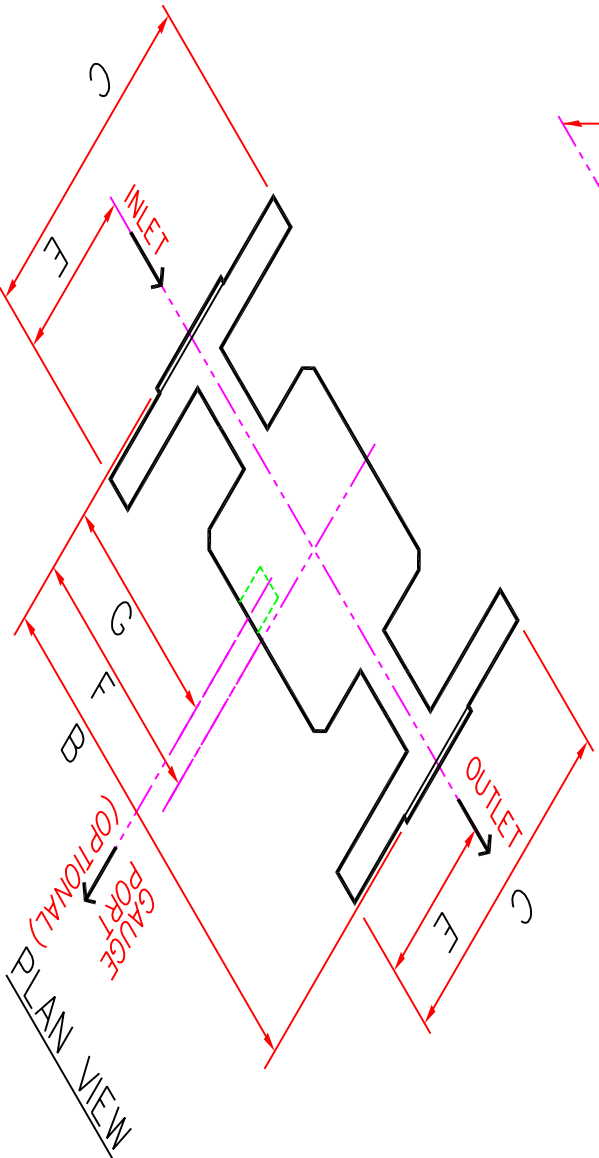
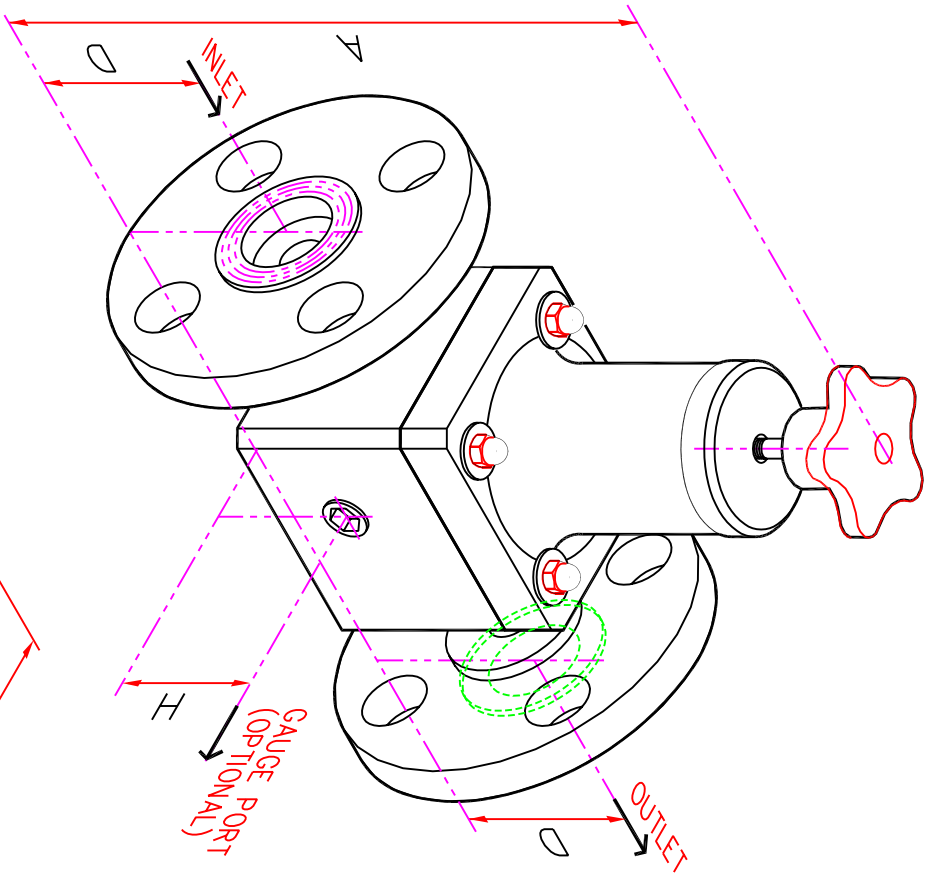

DO NOT COPY WITHOUT PRIOR WRITTEN APPROVAL FROM PRIMARY FLUID SYSTEMS.

Primary Fluid Systems Inc.
1050 COOKE BOULEVARD, BURLINGTON, ONTARIO L7T4A8

TOP VALVE BACK PRESSURE VALVE
FLANGED DIMENSIONS
POLYPROPYLENE & PVDF

SCALE	NIS	DISC	v12	DRAWN BY	BRB
DATE	11 03 03	APPROVED		DWG NO.	TVBFLGPP&P VDF
PROJECT				REV #	3