

DIMENSIONS (INCHES)

SIZE	OVERALL	INLET/OUTLET	PRESS. RELIEF	GAGE PORT (OPTIONAL)				
A**	B***	C	D***	E	F***	G***	H***	
1/4" x 1/2"			NOT AVAILABLE					
1/2"	8.51	7.52	3.50	2.91	1.75	3.76	3.23	2.91
3/4"	8.57	7.64	3.88	2.97	1.94	3.82	3.29	2.97
1"	9.03	8.06	4.25	3.33	2.125	4.03	3.56	3.33
1.5"	10.12	8.87	5.00	4.06	2.50	4.43	3.84	4.06
2"	11.00	9.63	6.00	4.70	3.00	4.81	4.22	4.70

* DIMENSIONS ARE APPROXIMATE FOR OVERALL HEIGHT BASED ON VALVE FACTORY SET AT 50 PSIG.

*** B, D, F, G & H DIMENSIONS BASED ON RAISED FACE FLANGES.

NOTE: RELIEF PORTS

1-1/2" VALVES (ALL MATERIALS) RELIEF PORT IS 1" FLANGE CONNECTION
 2" VALVES (ALL MATERIALS) RELIEF PORT IS 1-1/2" FLANGE CONNECTION

SUBJECT TO CHANGE WITHOUT NOTICE

TOLERANCE +/- 0.25"

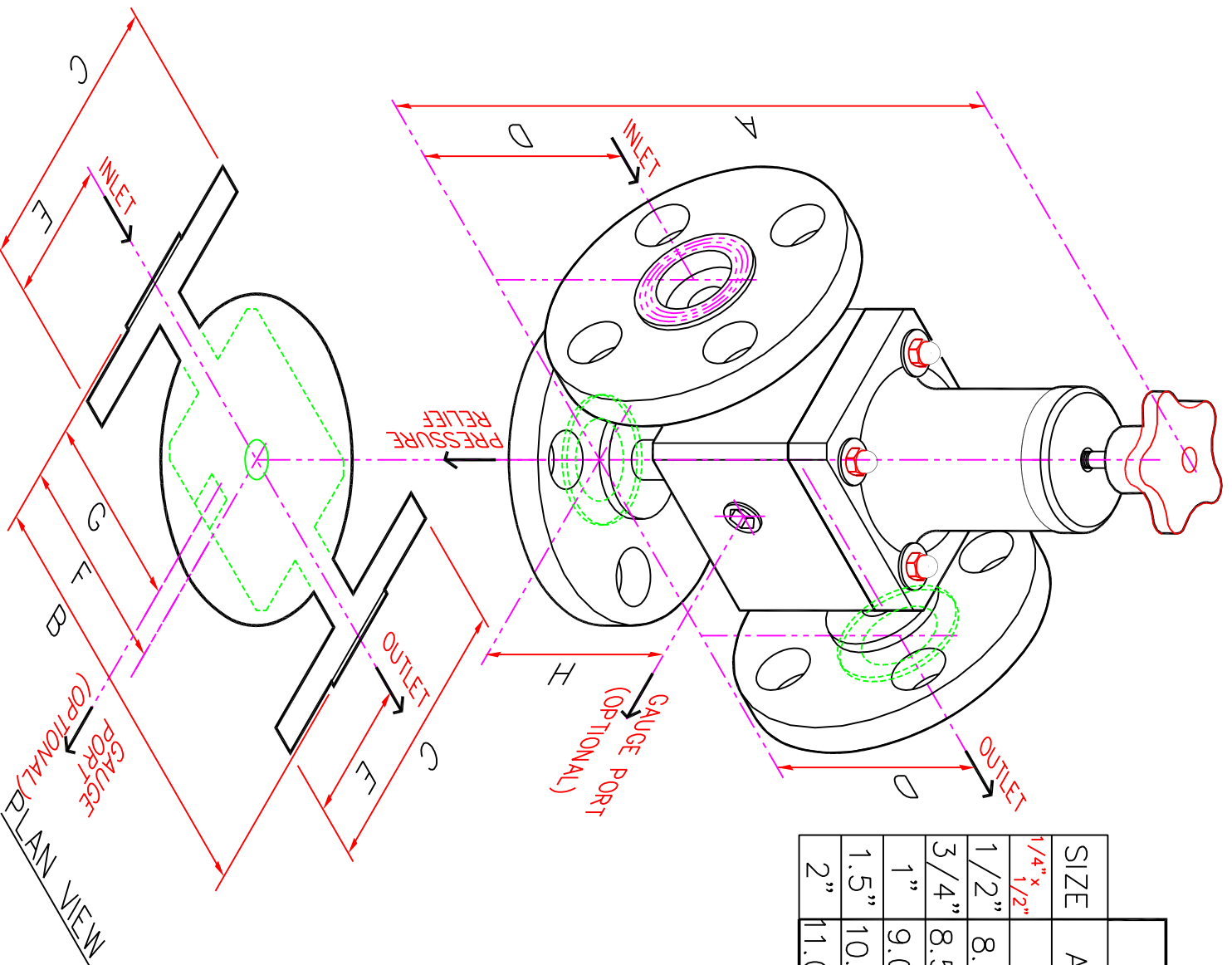

DO NOT COPY WITHOUT PRIOR WRITTEN APPROVAL FROM PRIMARY FLUID SYSTEMS.

Primary Fluid Systems Inc.

1050 COOKE BOULEVARD, BURLINGTON, ONTARIO L7T4A8

TOP VALVE PRESSURE RELIEF VALVE
 FLANGED DIMENSIONS
 ALLOY THREADED

SCALE	NTS	DISC	v12 DRAWN BY BGB	REV #
DATE	09 16 03	APPROVED	DWG NO.	
PROJECT			TPVFLGTHRDALLOY	1