

## DIMENSIONS (INCHES)

	OVERALL			INLET/OUTLET			GAGE PORT (OPTIONAL)		
SIZE	A*	B***	C	D	E	F***	G***	H	
1/4"x 1/2"	6.85	6.52	3.50	1.75	1.75	3.26	2.96	1.75	
1/2"	7.35	7.52	3.50	1.75	1.75	3.76	3.23	1.75	
3/4"	7.54	7.64	3.88	1.94	1.94	3.82	3.29	1.94	
1"	7.83	8.06	4.25	2.125	2.125	4.03	3.56	2.125	
1.5"	8.56	8.87	5.00	2.50	2.50	4.43	3.84	2.50	
2"	9.30	9.63	6.00	3.00	3.00	4.81	4.22	3.00	

\* DIMENSIONS ARE APPROXIMATE FOR OVERALL HEIGHT BASED ON VALVE FACTORY SET AT 50 PSIG.

\*\*\* B, F & G DIMENSIONS BASED ON RAISED FACE FLANGES. SUBJECT TO CHANGE WITHOUT NOTICE TOLERANCE +/- 0.25"

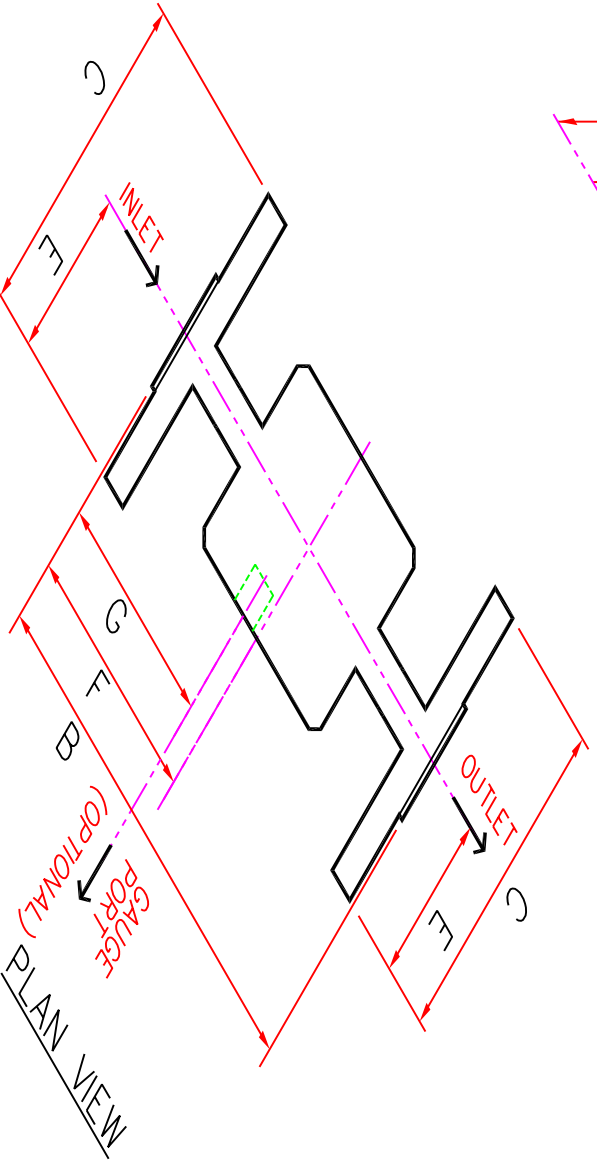
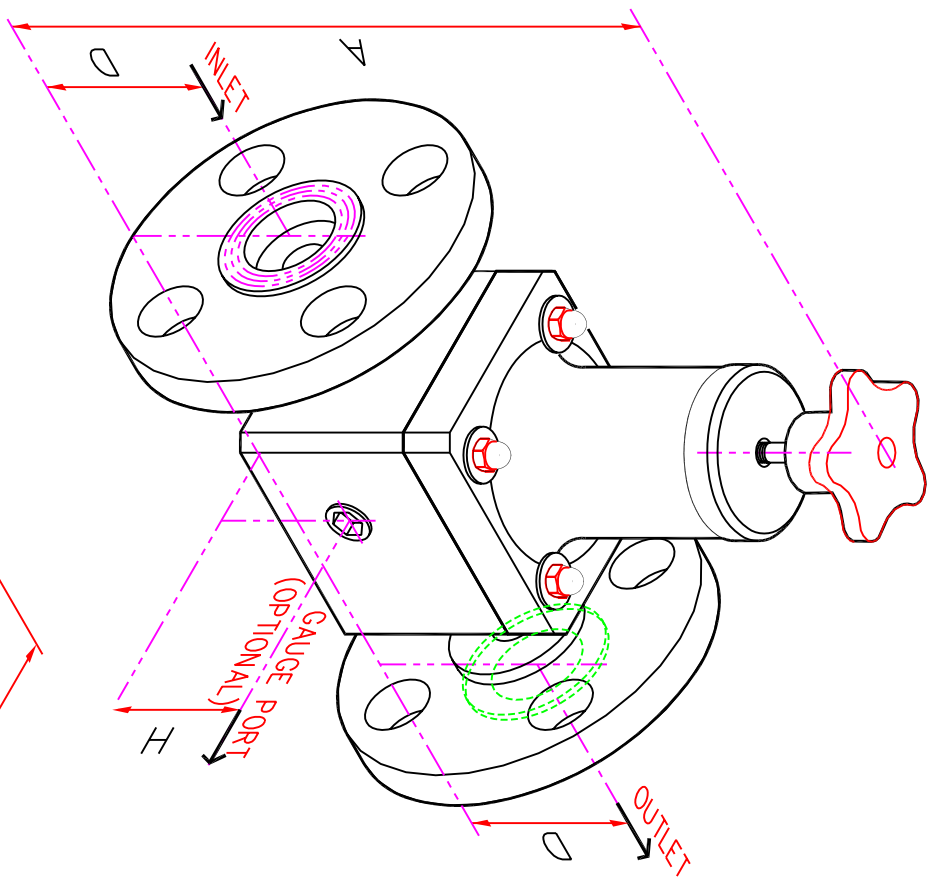

**Primary Fluid Systems Inc.**  
1050 COOKE BOULEVARD, BURLINGTON, ONTARIO L7T4A8

---

TOP VALVE BACK PRESSURE VALVE  
FLANGED DIMENSIONS  
ALLOY THREADED

---

DO NOT COPY WITHOUT PRIOR WRITTEN APPROVAL FROM PRIMARY FLUID SYSTEMS.

SCALE	NTS	DISC	V12 DRAWN BY BCB
DATE	09 16 03	APPROVED	DWG NO.
PROJECT			TVBFLGTHRDALLOY