

THIS DRAWING IS THE PROPERTY OF PRIMARY FLUID SYSTEMS INC. FROM WHICH A WRITTEN CONSENT FOR APPROVAL SHALL BE REQUIRED PRIOR TO COPYING.

| NO. | NAME | DESCRIPTION |
|------------------------|-------------------------------------|------------------------------------|
| 1 | MAX ALLOWABLE OPERATING TEMPERATURE | 140°F (60°C) |
| 2 | MAX ALLOWABLE OPERATING PRESSURE | 150 PSIG @ 70°F |
| CONNECTIONS | | |
| 3 | SIZE: INLET/OUTLET | 3/4" |
| 4 | CONNECTION TYPE | ANSI B16.5 FLANGE |
| MATERIALS (WETTED) | | |
| 5 | BODY | PVC |
| 6 | DIAPHRAGM | VITON/EPDM/PTFE |
| MATERIALS (NON-WETTED) | | |
| 7 | FLANGE | PVC |
| 8 | SPRING BONNET/TOP | CPVC |
| 9 | SPRING | NICKEL PLATED MUSIC WIRE ASTM A228 |
| 10 | TOP/BOTTOM DISC | POLYPROPYLENE |
| 11 | BOLTS, NUTS, WASHERS | STAINLESS STEEL |
| 12 | FACTORY SET PRESSURE | 50 PSIG |
| 13 | SPRING RANGE | 7-150 PSIG |

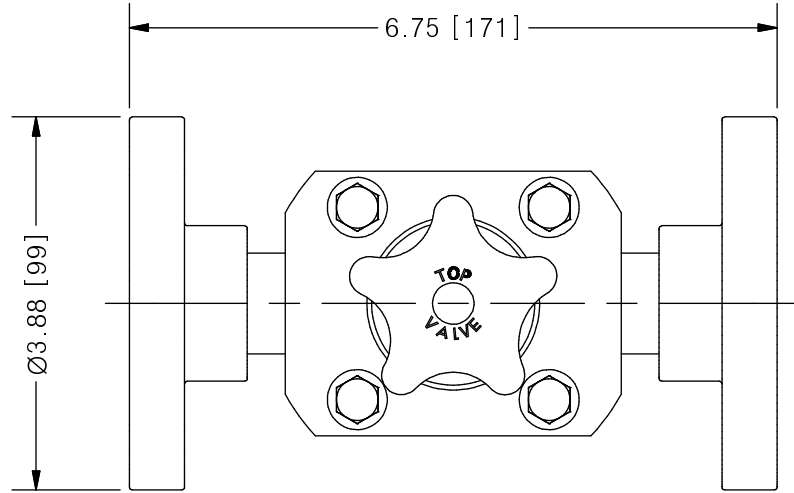

TOP VALVE® TVB BACK PRESSURE VALVE

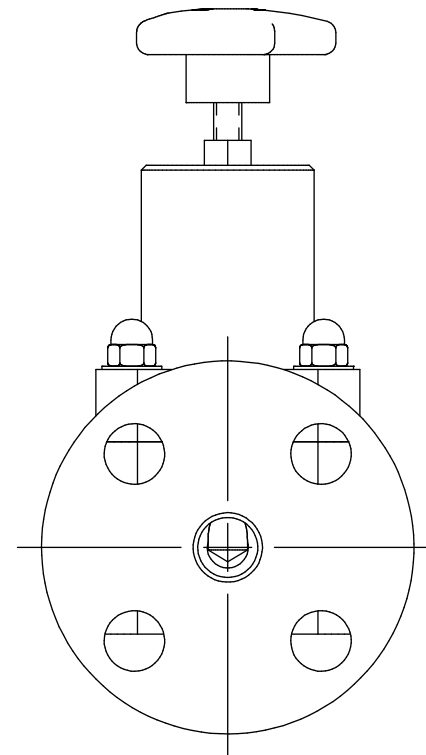
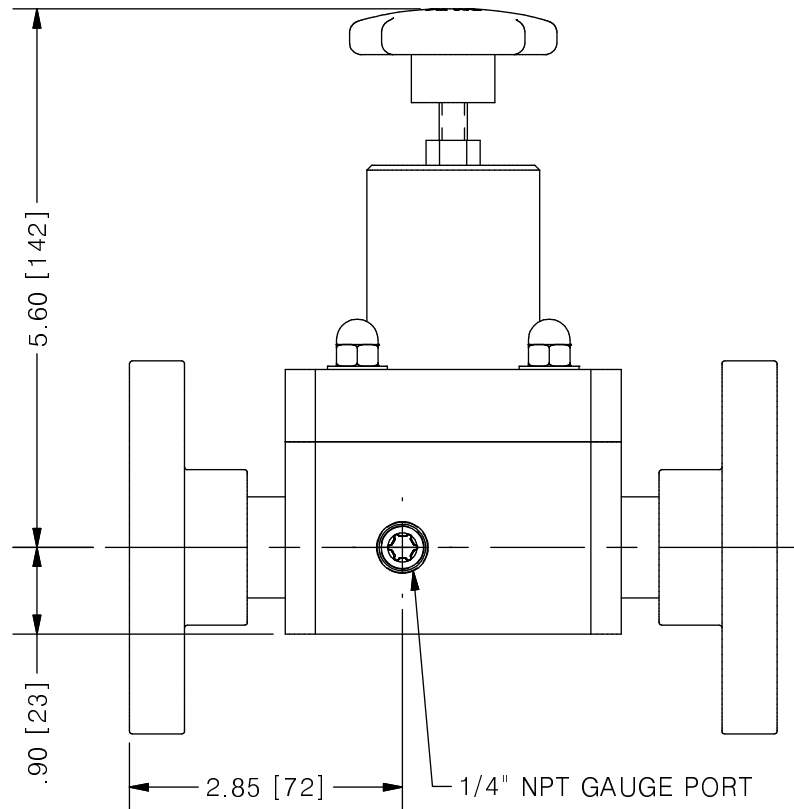
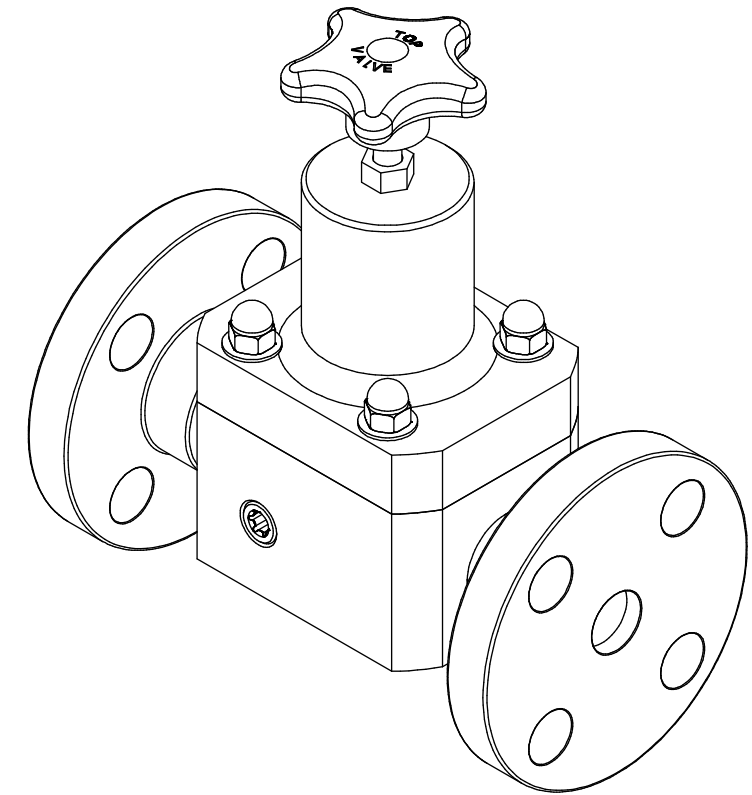

SCALE 1 : 2

| REV | DESCRIPTION | DATE | NAME |
|-----|-------------|------|------|
| 0 | NEW DRAWING | -- | -- |

REVISION HISTORY

| | | | | |
|--|--|----------------------|--------------|---|
| PRIMARY FLUID SYSTEMS INC. 1050 COOKE BLVD, BURLINGTON, ONTARIO L7T 4A8 | | PROJECT: TVB | SHT: 1 OF 1 | DRAWN BY: BRJB |
| TITLE: 3/4" BACK PRESSURE TOP VALVE WITH 3/4" 150# SW FLANGE CONNECTIONS PLUS GAUGE PORT | | DATE DRAWN: 6/2/2017 | SCALE: 1 : 2 | UNITS: INCH [mm] |
| DWG NO: TVBF75-PVC-G_R0 | | MATERIAL: SEE CHART | REV# 0 | |
| DWG NAME: TOP VALVE DWG TYPE: PLANAR VIEW | | APPROVED BY: | CHECKED BY: | DIMENSIONAL TOLERANCE 0.XX = ± 0.25" 0.XXX = ± 0.25" 0.XXX = ± 0.25" |
| THIRD ANGLE PROJECTION | | | | SHEET SIZE: B |