

THIS DRAWING IS THE PROPERTY OF PRIMARY FLUID SYSTEMS INC. FROM WHICH A WRITTEN CONSENT FOR APPROVAL SHALL BE REQUIRED PRIOR TO COPYING.

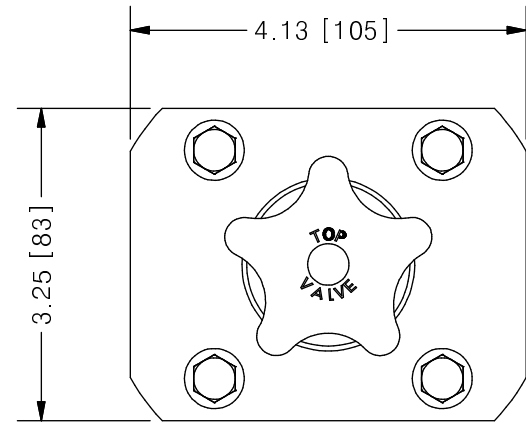

TOP VALVE® TVP PRESSURE RELIEF VALVE

	NO.	NAME	DESCRIPTION
	1	MAX ALLOWABLE OPERATING TEMPERATURE	140°F (60°C)
	2	MAX ALLOWABLE OPERATING PRESSURE	150 PSIG
CONNECTIONS	3	SIZE: INLET/OUTLET PORTS	1-1/2"
	4	SIZE: RELIEF PORT	1"
	5	CONNECTION TYPE	NPT
MATERIALS (WETTED)	6	BODY	PVC
	7	DIAPHRAGM	PTFE BACKED EPDM
MATERIALS (NON-WETTED)	8	SPRING BONNET/TOP	PVC
	9	SPRING	NICKEL PLATED MUSIC WIRE ASTM A228
	10	TOP/BOTTOM DISC	POLYPROPYLENE
	11	BOLTS, NUTS, WASHERS	STAINLESS STEEL
	12	FACTORY SET PRESSURE	50 PSIG
	13	SPRING RANGE	7-150 PSIG

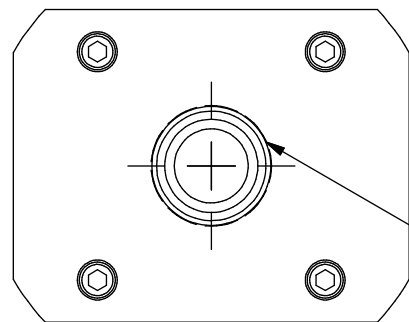
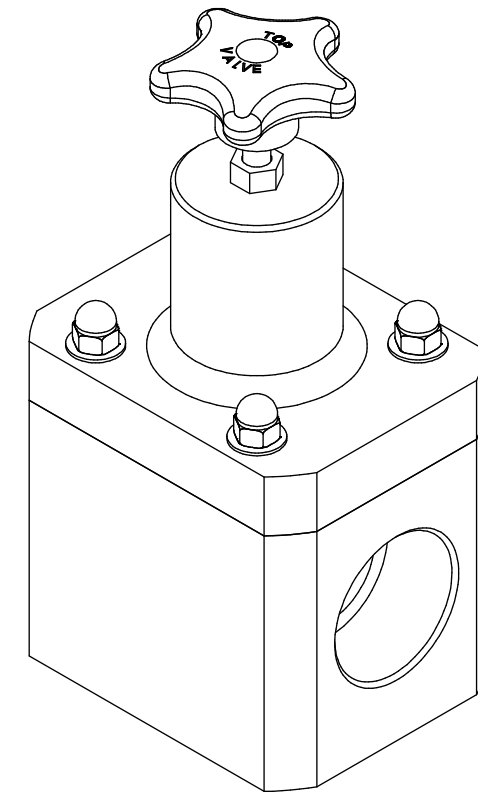
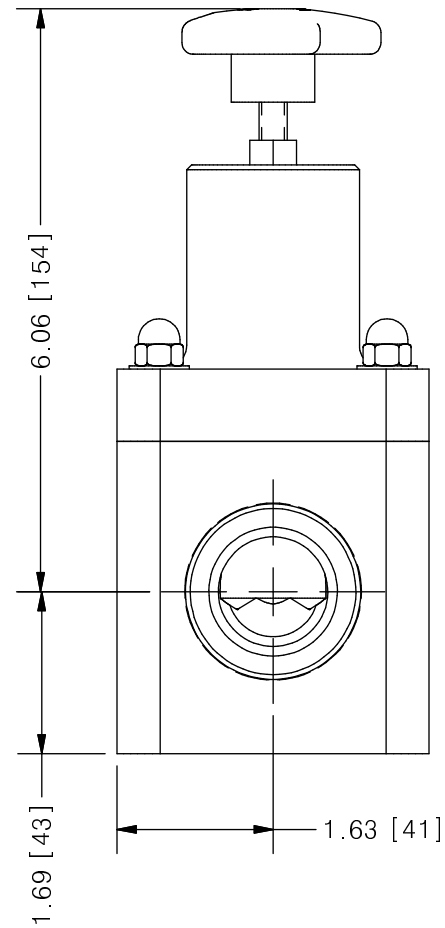
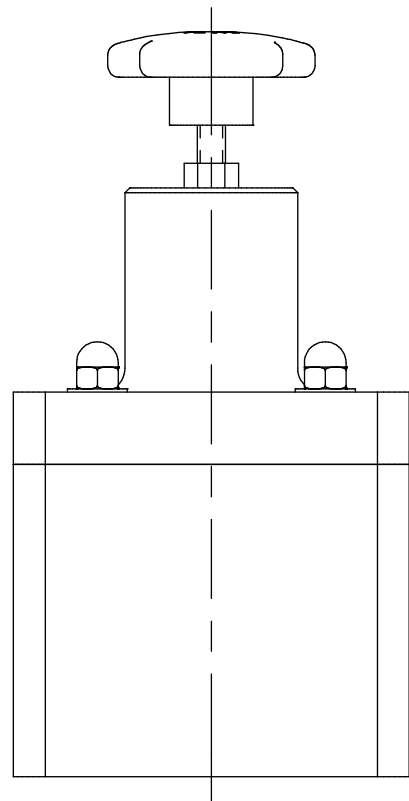

1" NPT RELIEF PORT

SCALE 1 : 2

0	NEW DRAWING	--	--
REV	DESCRIPTION	DATE	NAME
REVISION HISTORY			

PRIMARY FLUID SYSTEMS INC. 1050 COOKE BLVD, BURLINGTON, ONTARIO L7T 4A8		PROJECT: TVP	SHT: 1 OF 1	DRAWN BY: NG
TITLE: 1-1/2" PRESSURE RELIEF TOP VALVE WITH 1-1/2" AND 1" NPT CONNECTIONS		DATE DRAWN: 8/1/2016	SCALE: 1 : 2	UNITS: INCH [mm]
DWG NO: TVPR15-PVC_R0		MATERIAL: SEE CHART	REV# 0	
DWG NAME: TOP VALVE		APPROVED BY:	CHECKED BY:	DIMENSIONAL TOLERANCE 0.X = ± 0.25" 0.XX = ± 0.25" 0.XXX = ± 0.25"
DWG TYPE: PLANAR VIEW				11 X 17 SHEET SIZE: B